

Standard Sailing Instructions

Template

In accordance with RRS Part. 7, 89.1(d) the organizing authority for all Class Championships and Sanctioned Regattas is the Snipe Class International Racing Association. Event Hosts (affiliated clubs or organizations) shall use these Sailing Instructions for all Championship and Sanctioned regattas. The Principal Race Officer (PRO) for the regatta shall fill in the appropriate information where requested as indicated by <____> or delete sections not relevant. Specific advice and directives are bracketed [*-*]. No additions or deletions to these instructions shall be permitted to alter the intent of the Class rules. No additions or changes shall be made without the prior approval of the regatta SCIRA Representative.

SAILING INSTRUCTIONS

SNIPE CLASS INTERNATIONAL RACING ASSOCIATION

<Name of the Regatta>
<Name of Deed of Gift Trophy>
<Date>
<Name of Yacht Club>
<Location>

Notation [NP]

The notation [NP] in a rule in the SI means that a breach of this rule shall not be grounds for a protest by a boat.

Notation [SP]

The notation [SP] in a rule in the SI means that for a breach of this rule a standard penalty will be applied.

Notation [DP]

The notation [DP] in a rule in the SI means that for a breach of this rule a discretionary penalty will be applied.

1 RULES

1.1 The regatta will be governed by the rules as defined in The Racing Rules of Sailing.

1.2 The National prescription that applies will be <insert prescriptions>.

OR

No National prescription will apply.

1.3 The Rules of Conduct for Conducting National and International Championship and the trophy restrictions of <insert the name of trophy and Deed of Gift> will apply. Any conflict arising between the Deed of Gift and the SCIRA Rules of Conduct shall be solved by the application of the Rules of Conduct.

1.4 In case of conflict between the Notice of Race and the Sailing Instructions the Sailing Instructions shall prevail.

1.5 If there is a conflict between languages the English text will take precedence.

2 NOTICES TO COMPETITORS

Notices to competitors will be posted on the official notice board(s) located at <Insert location(s)>.

3 CHANGES TO SAILING INSTRUCTIONS

3.1 Any change to the sailing instructions will be posted before <insert time> on the day it will take effect, except that any change to the schedule of races will be posted by <insert time> on the day before it will take effect.

3.2 Any change or amendment to the Sailing Instructions shall be approved with the SCIRA Representative.

4 SIGNALS MADE ASHORE

4.1 Signals made ashore will be displayed at <Insert location>.

4.2 When the "AP" race signal is displayed ashore, '1 minute' is replaced with 'not less than <Insert number of minutes> minutes' in the race signal "AP".

4.3 [NP] [DP]. When the "AP over H" race signal is displayed ashore, the boats shall not leave the harbour. The warning signal will be exposed no less than <Insert number of minutes> after the signal is lowered with one sound

5 SCHEDULE OF RACES

5.1 Dates of racing:

Table with 3 columns: Date, Time of Warning Signal, and Race Type. Race types include Practice race, Racing, Lay day, Racing, and Reserve day.

- 5.2 The regatta shall consist of <insert number> races.
- 5.3 No more than **two (2) races shall be sailed per day; three (3) races can be sailed only if behind schedule.** No more than two (2) races shall be sailed per day for Masters events.
- 5.4 [*Optional*] The regatta shall consist of a qualifying and a final series according to the following system: <Insert system>.
- 5.6 In case of a prolonged postponement, to alert boats that a race or sequence of races will begin soon, an orange flag will be displayed with one sound for at least four minutes before a warning signal is made. Failures to observe this instruction are not grounds for redress.
- 5.7 On the last day of racing no warning signal will be made after <Insert time>.
- 5.8 There will be a competitors meeting before each series, at <insert time and location> and announced by two <insert type of sound signals>.

6 CLASS FLAGS

The official Class Flag shall be the Snipe Class flag, a red Snipe on a white background.

7 RACING AREAS

Attachment <Insert number or letter> shows the location of racing areas.

OR

The Racing Area location chart is posted on the Official Notice Board

OR

The Racing Area location is <describe location>.

8 WEATHER LIMITATION (Course and Starting)

The wind speed ranges shall be no less than 5 knots and not exceed 23 knots or in accordance with the applicable Deed of Gift. For Masters events the maximum wind speed allowed shall be 15 knots. For Women's events the maximum wind speed allowed shall be 18 knots.

9 THE COURSES

- 9.1 The diagrams below show the courses, including the approximate angles between legs, the order in which marks are to be passed. All course marks (except gates) shall be left to port.

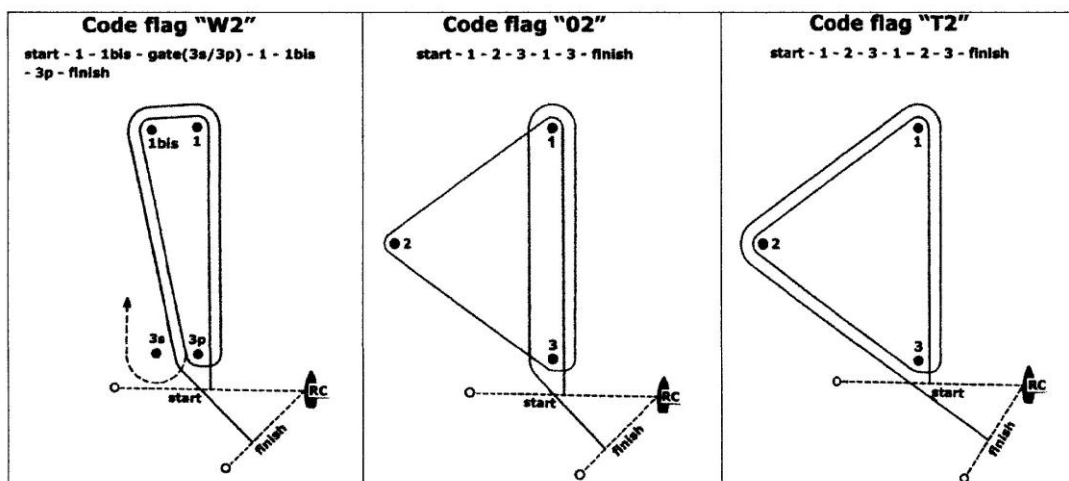
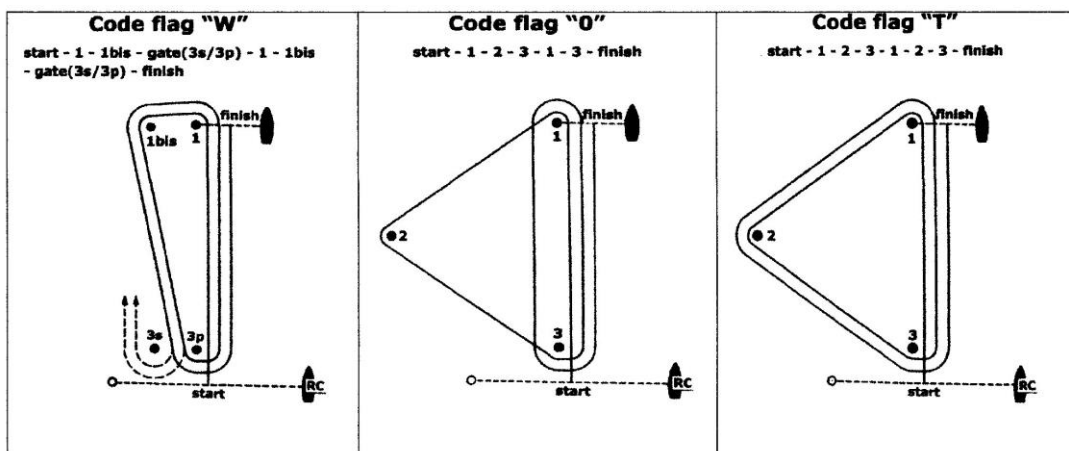

- 9.2 The course signal (code flag “W”, “T”, “O”, “W2”, “T2” or “O2”) shall be hoisted with one sound at last one minute before the warning signal. It will remain displayed for not less than five minutes after the start.
- 9.3 No later than the warning signal, the Race Committee signal boat will display the approximate compass bearing of the first leg.
- 9.4 If during a race the wind and/or wave action changes to the point where the selected course would be inadvisable (See Course Selection Diagram), the Race Committee shall change the course at any mark. A change of the type of course during the race shall be signalled displaying the new appropriate flag and accompanied by repetitive sounds before the leading boat has passed or rounded the mark.
- 9.5 The number of legs in a race may be reduced (RRS code flag S) but at least 2 (two) windward legs of the race shall be completed. This changes the RRS 32.2. [*The SCIRA Representative shall be consulted.*]
- 9.6 A sustained wind variation of 20 degrees or more from the posted bearing during the first leg of a race shall result in the race to be abandoned and re-sailed, or abandoned. This changes the RRS 32.1.
- 9.7 A sustained wind variation of 40 degrees or more from the posted bearing during the first lap shall result in the race being abandoned and re-sailed, or abandoned. For the purpose of this rule a lap means the rounding of mark 3 (or passing the gate 3s-3p) for the first time. This changes the RRS 32.1.

10 MARKS

- 10.1 Marks 1, 1bis, 2, 3, 3s and 3p will be <Describe marks>.
- 10.2 New marks, as provided in instruction 13.1, will be <Describe new marks>.
- 10.3 The port-end starting mark will be:
a) a boat with an orange flag displayed;
or:
b) a inflatable rubber buoy <Describe new mark>.
- 10.4 The finishing mark will be:
- mark 1 for “W”, “O”, and “T” courses;
- a buoy with a orange flag displayed for “W2”, “O2”, and “T2” courses
- 10.5 A Race Committee vessel signalling a change of a leg of the course is a mark as provided in SI 13.2.
- 10.6 If one of the marks "gate 3s-3p" is not placed, or is not replaced as per RRS 34, the remaining mark shall be left to port. This changes the RRS 34.

11 AREAS THAT ARE OBSTRUCTIONS [*Optional*]

The following areas are designated as obstructions: <Describe obstruction areas>.

12 THE START

- 12.1 RRS 30.4 (‘Black Flag Rule’) shall not be used.
- 12.2 The starting line will be between a staff displaying an orange flag on the Race Committee vessel at the starboard end and:
a) a staff displaying an orange flag on the starting mark as provided in instruction 10.3 a).
OR
b) the course side of the starting mark as provided in instruction 10.3 b).
- 12.3 A boat starting later than 5 minutes after her starting signal will be scored Did Not Start without a hearing. This changes Appendices A4 and A5.
- 12.4 The Race Committee, after the finish of a race and before the warning signal of a subsequent one, will do its best to post on the Race Committee vessel a list of OCS, or ZPF, or UFD boats. The failure of posting or an incomplete or wrong list will not be grounds for redress. This changes the RRS 62.1(a).

13 CHANGE OF THE NEXT LEG OF THE COURSE

- 13.1 To change the next leg of the course, the Race Committee will lay a new mark (or move the finishing line) and remove the original mark as soon as practicable. When in a subsequent change a new mark is replaced, it will be replaced by an original mark.
- 13.2 Except at a gate, boats shall pass between the race committee boat signalling the change of the next leg and the nearby mark, leaving the mark to port and the Race Committee vessel starboard. This changes the RRS 28.
- 13.3 After the completion of first windward leg of the race the remaining legs may be increased or decreased by not more than 30% of the original length. This changes the RRS 33). [*The SCIRA Representative shall be consulted on any change of course which affects its length.*]
- 13.4 If Mark 1 will be changed in courses “W” or “W2”, Mark 1bis (offset) will no longer be a course mark.

14 THE FINISH

- 14.1 The finish line will be between a staff displaying an orange flag on a Race Committee vessel and the course side of the finishing mark *OR* the staff displaying an orange flag on the finishing buoy as provided in 10.4.
- 14.2 The A flag on the Race Committee boat at the finish means that there will be no more races for the day.

15 PENALTY SYSTEM

Appendix P will apply.

16 TIME LIMITS AND TARGET TIMES

- 16.1 The races will be managed to last 60-75 minutes for the first boat to finish. A different time (shorter or longer) used to complete the race will not be ground for requesting redress.
- 16.2 The time limit for the first boat to complete the first lap is 40 minutes from the start. If the first boat fails to complete the first lap within 40 minutes the Race Committee shall abandon the race. For the purpose of this rule a lap means the rounding of Mark 3 (or passing the Gate 3s/3p) for the first time.
- 16.3 The time limit for the first boat to finish the race shall be 1 hour, 30 minutes. Any boat finishing more than 30 minutes after the first boat finishes or failing to finish within 2 hours from the start, whichever is shorter shall be scored Did Not Finish (DNF). This changes RRS 35, A4 and A5.

17 PROTESTS AND REQUESTS FOR REDRESS

- 17.1 [*Optional*] Appendix T will apply.
- 17.2 Protest forms are available at the race office, located at <Insert location>. Protests and requests for redress or reopening shall be delivered there within the appropriate time limit.
- 17.3 The protest time limit is 90 minutes after the last boat has finished the last race of the day or the Race Committee signals no more racing today, whichever is later.
- 17.4 Notices will be posted no later than 30 minutes after the protest time limit to inform competitors of hearings in which they are parties or named as witnesses. Hearings will be held in the protest room, located at <Insert location>, beginning at the time posted.
- 17.5 Notices of protests by the Race Committee, Technical Committee or Protest Committee will be posted to inform boats under RRS 61.1(b).
- 17.6 A list of boats that have been penalized for breaking RRS 42 will be posted on the Official Notice Board.
- 17.7 A list of boats that have been penalized for breaking RRS 29.1(OCS) or 30.1(OCS) or 30.2(ZPF) and 30.3(UFD) will be posted on the Official Notice Board.
- 17.8 Breaches of rules in the SI marked with [NP] and NoR 3.4 (bow numbers) will not be grounds for a protest by a boat. This changes the RRS 60.1(a).
- 17.9 The penalty for breaking rules in the SI marked with [SP] and NoR 3.4 (bow numbers) may be applied at the discretion of the Race Committee, without a hearing, and shall be the 5% scoring penalty for nearest race completed by the infringing boat but not worse than the number of points corresponding to DSQ. This changes the RRS 63.1 and the App.A5.
- 17.10 The penalty for breaking rules in the SI marked with [DP] may be applied at the discretion of the Protest Committee.
- 17.11 Penalties for breaking Class Rules may be less than disqualification.
- 17.12 A list of boats that have been penalized as per SI 17.9 and 17.10 will be posted on the Official Notice Board.
- 17.13 On the last scheduled day of racing a request for redress based on a protest committee decision shall be delivered no later than 30 minutes after the decision was posted. This changes the RRS 62.2.
- 17.14 [*For regattas employing an international jury*] An International Jury is constituted and shall have authority per RRS Appendix N. Their decision shall be final as provided in RRS 70.5. Per Appendix N2.2, SCIRA reserves for itself the right and responsibility to decide issues of eligibility, measurement and equipment. SCIRA may refer any issue to the International Jury for advice.
- 17.15 The use of team racing tactics shall not be tolerated.
- 17.16 For the purpose of RRS 64.3(b) the “authority responsible” is the Measurer of the event.
- 17.17 The Jury will abandon the race if, during a redress hearing, they conclude that the Race Committee did not follow Sailing Instructions 8, 9.5, 9.6, 9.7, and 13.3. This changes the RRS 64.2.

18 SCORING

- 18.1 <Insert number> races are required to be completed to constitute a series. [*per SCIRA Rules, Deed of Gift, etc.*]
- 18.2 (a) When fewer than <Insert number> races have been completed, a boat’s series score will be the total of her race scores.
- (b) When from <Insert number> to <Insert number> races have been completed, a boat’s series score will be the total of her race scores excluding her worst score.
- (c) When <Insert number> or more races have been completed, a boat’s series score will be the total of her race scores excluding her two worst scores.
- 18.3 A boat intending to retire and be scored RET shall report its intent in writing to the Race Committee or the Jury within the protest time limit.

19 [NP][SP] SAFETY REGULATIONS

- 19.1 Before the warning signal of the first race of the day each boat is required to sail past the stern of the <insert description> Race Committee boat on starboard tack and verbally check in. The check-in boat will display a <insert flag description> while on station prior to the first warning signal. If no separate check-in boat is on station competitors will check in with the main Race Committee boat. When the Race Committee verbally acknowledges a boat’s <insert sail or bow> number, the check-in has been officially noted.
OR
- 19.1 Check-Out and Check-In: <Describe any Check-Out or Check-In Procedures>.
- 19.2 A boat that retires from a race (DNF) shall notify the Race Committee as soon as possible.

- 20 REPLACEMENT OF CREW OR EQUIPMENT
- 20.1 The same crew shall race in all races, except for reasons satisfactory to the Race Committee. Requests for a change of crew shall be submitted in writing to the Chairman. Once a crew has been excused, he/she may not return for the balance of the series.
- 20.2 The same skipper shall sail all races and can be replaced after the first race only, and then only if he/she is obviously incapacitated. If a skipper is replaced the first race shall be the race dropped, or scored DNC.
- 20.3 [NP] Substitution of damaged or lost equipment will not be allowed unless authorized by the Race Committee. Requests for substitution shall be made to the Race Committee at the first reasonable opportunity.
- 21 [NP] EQUIPMENT AND MEASUREMENT CHECKS
- A boat or equipment may be inspected at any time for compliance with the Class Rules and Sailing Instructions. On the water, a boat can be instructed by a member of the Race Committee, or the Technical Committee, or the equipment inspector or measurer, to proceed immediately to a designated area for inspection.
- 22 [NP][SP] EVENT ADVERTISING
- Boats shall display event advertising supplied by the organizing authority as follows:
<Insert necessary information about supplied advertising material>.
- 23 RIGHTS TO USE NAME AND LIKENESS
- By participating in this event, competitors automatically grant to the SCIRA, organizing authority and the event sponsors the right, in perpetuity, to make, use, and show, at their discretion, any photography, audio and video recording, and other reproductions of them made at the venue or on the water from the time of their arrival at the venue, until their final departure, without compensation.
- 24 OFFICIAL BOATS
- Official boats will be marked as follows: <Describe markings>.
- 25 [NP] [DP] SUPPORT BOATS
- 25.1 Team leaders, coaches and other support personnel shall not go afloat in the racing area during the racing except upon Race Committee designated spectator boats. The Race Committee may initiate additional restrictions by posting them on the Official Notice Board.
- OR
- 25.1 At the preparatory signal, coaches must be positioned at least 50 meters below the starting line. After the starting signal coaches may follow the fleet, but only on the port side of the course and must stay 50 meters from any mark
- 25.2 Coaches may not communicate with competitors after the warning signal for any race until after the competitors have finished of the race.
- 25.3 Coaches shall register at the Regatta Office and all support boats shall be identified <insert how to identify>.
- 26 RADIO COMMUNICATIONS
- A boat shall neither make or receive radio transmissions while racing nor receive radio communications not available to all boats, except in an emergency or when using equipment provided by the race committee. This restriction also applies to mobile telephones.
- 27 [NP] [DP] TRASH DISPOSAL
- Trash may be placed aboard support and Committee Vessels.
- 28 PRIZES
- Prizes shall be awarded as provided by NoR.

Signatures: [* The Sailing Instruction must be signed by the Race Committee Chairman or Principal Race Officer and also the SCIRA Representative*]

<insert name> - Race Committee Chairman

<insert name> - SCIRA Representative

Optional Addendum (Large Fleets)

[*any or all of these options may be used*]

The Start:

11.6 Mid-line boat

- 11.6.1 The starting line shall be between an orange flag or shape on the Race Committee boat on the starboard line end and passing through an orange flag or shape on the mid-line boat and ending at the line flag or the course side of the port end starting mark. The mid-line boat is a starting mark surrounded by navigable water. Should the mid-line boat be removed, the line shall be defined by the previously described line ends.
- 11.6.2 For the purpose of RRS 28.1 and 30.1, the extensions of the starting line are beyond the port and starboard line ends.
- 11.6.3 RRS 31.2 is modified such that when a boat touches the mid-line boat and infringes RRS 30.1, she shall exonerate herself by completing one rounding of either line end and restarting.
- 11.7 The Race Committee may set a guidance marker on or below the starting line. If set, such a marker is neither a part of the starting line, nor a mark of the course.

Scoring:

18.3 (Optional for drop race regattas)

RRS 62 is modified such that a violation of RRS 29.1 (OCS) may not be dropped if unsuccessfully contested by the infringing competitor and shall be scored DNE.